

Engine

Yanmar Tier 4, Stage IIIB

Gross Power

50 - 54 kW (67 - 72 hp)

Operating Weight

3,100 - 3,750 kg (6,820 - 8,267 lbs)

Bucket Capacity

0.4 - 0.5 m³ (0.59 - 0.65 yd³)

375B/385B

SKID STEER LOADER



TOUGH WORLD. TOUGH EQUIPMENT.

MAXIMUM RETURN ON YOUR INVESTMENT



DEPENDABLE POWER

Unmatched performance driven by Yanmar engine meets strict EPA Tier 4 & EU Stage IIIB emissions standards - maximizing torque output and delivering more power at lower engine speeds. ECU improves fuel efficiency.

SPACIOUS CAB

Oversized cab is designed for safety and comfort with FOPS and ROPS.

VERSATILITY

Variable attachments can be chosen for different needs. Increased flexibility to handle more jobs with just one machine.

SELF-LEVELING VALVE

The self-leveling valve maintains an even level and keeps the highly stable design more balanced, which prevents bucket spillage and improves working efficiency.

FOUR WHEEL DRIVE

Four wheel hydraulic drive provides excellent traction, with durable driving chains.

EASY FOR SERVICE

80 degree back-tilting cab and a large rear compartment door provide safe and simple access to all service and maintenance areas.

AFTER SALES SERVICE

As a customer of LiuGong you can feel confident that our dealers and regional offices will be there to support you with training, service and maintenance needed throughout the life of your machine.

DESIGNED TO GET MORE DONE

POWERFUL PERFORMANCE

The 375B/385B comes equipped with a fuel efficient Yanmar Tier 4 engine that produces gross power of 50 kW (67 hp) - 54 kW (72 hp) at 2,400 rpm with high peak torque.

The engine is connected to a drive piston pump allowing the power transfer to the hydraulic system directly. With ECU, you can get better fuel economy.

OPTIMIZED HYDRAULICS

Two hydraulic systems: a closed circuit for driving and an open circuit for working. The driving circuit includes a highly efficient piston pump and a motor. The working circuit adopts pilot control; system flow reaches 18.3-31.8 gal/min (69-120 L/min).

ALWAYS RELIABLE

We are committed to
reducing your total
cost of ownership and
increasing your profits.

EXCELLENT STABILITY FRAME

Mono-block frame ensures excellent stability and increased strength. Trapezoid box frame of boom is designed for high power and good stability and handles shocks and torsion well. It is also designed for high-frequency rock breaking.

SELF-LEVELING LINKAGE

The self-leveling valve maintains an even level and keeps the highly stable design more balanced, this levelling also prevents bucket spillage bucket making work more efficient.

HIGH EFFICIENCY FILTER

The filter restricts dust and particles from entering the engine, protecting the engine from wear, extending engine service life and improving engine efficiency.





OPERATOR'S COMFORT AND SAFETY

ROLL-OVER PROTECTION SYSTEM

The cab's high-strength ROPS ensures operator protection in a worst-case scenario.

FALLING OBJECT PROTECTION SYSTEM

In the extreme environments, the 375B/385B is designed to work in. The choice of Falling Object Protection System (FOPS) is an invaluable addition to operator safety.

COMFORT OPERATING CONDITION

Adjustable seat with shock absorption and optional high - grade seat provide utmost comfort to the operators. The cab is equipped with easy-pull and easy-secure side windows. Other options include radio with MP3.

CONVENIENT TO CONTROL

Ergonomic low-effort pilot control joysticks reduce operator's fatigue. The switches on the joysticks control the auxiliary kits by fingertips.



PART OF YOUR PERFORMANCE

No matter where you are in the world, we can ensure **fast and efficient** parts support to keep you going.



We know that what you want is to be confidence in your machinery. So we make sure we can always get what you need without delay, without fail, without excuses. Anywhere, and at any time. That's more than our goal. That's our pledge.

LiuGong engineering sets high standards and all parts are rigorously tested to ensure they can meet the rigid quality specifications required for long lasting performance.

READY FOR ANY JOB

LiuGong provides a range of purpose designed attachments, hitches and tools for your 375B/385B to give you increased versatility for any job site. In - cab dial - in hydraulic flow settings through the display screen optimizes the attachment performance.



BUCKETS

SWEEPER

PLANDER

BREAKER

EASY FOR MAINTENANCE

24 DEGREE TAPERED SEALS WITH O-RINGS

24 degree tapered seals with O-rings are fitted on hose connections to eliminate hydraulic leakage. The excellent design contributes to your machine's uptime and reduces service costs by providing a 100% leak free joint.

CAB TILT

The entire cab can easily be tilted backward by one person with 80 degrees to provide adequate space for the replacement of engine fuel filter, hydraulic oil filter, and more.

EXCELLENT LAYOUT

The hydraulic pipes and electrical wires are well reorganized and positioned to provide adequate space for daily inspection and convenient maintenance.

All fuseboxes and relays are centralized and easily accessible.

REAR SERVICE ACCESS

Rear hood provides adequate space for adding diesel or hydraulic oil, replenishing engine oil and anti-freeze fluid, replacing the air filter, draining the fuel water separator.



WHERE YOU NEED US WHEN YOU NEED US

LiuGong is committed to providing **reliable** and **tough** equipment combined with dependable service to customers **across the globe**.



GLOBAL NETWORK

We offer local support through our extensive dealer network in more than 130 countries. Our dealers and customers are supported by 10 regional subsidiaries and 9 global parts centers, all offering expert training, parts and service support.

PROFESSIONAL ADVICE

No matter the job, we can help you choose the right machine, with the right specifications, options and attachments for your business. We are committed to ensure maximum uptime and lowest cost of ownership to ensure you get good profitable return from your equipment.

SERVICE AGREEMENTS

At LiuGong, we offer service agreements to support your business needs and help you take control of all your costs. Talk to us today.



SPECIFICATIONS

OPERATING WEIGHT		375B	385B
Operating Weight		6,820 lbs (3,100 kg)	8,267 lbs (3,750 kg)
ENGINE			
Emission Regulation	EPA Tier4F & EU Stage IIIB		
Make	Yanmar		
Number of Cylinders	4		
Displacement	201 in ³ (3.3 L)		
Cooling Type	Water		
375B			
Model	4NV98C-PLYS		
Gross Power	67 hp (50 kW) @ 2,400 rpm		
Peak Torque	64 lbf·ft (241 N·m) @ 1,625 rpm		
385B			
Model	4NV98CT-NLYS		
Gross Power	72 hp (53.7 kW) @ 2,400 rpm		
Peak Torque	77 lb · ft (291 N · m) @ 1,625 rpm		
ELECTRICAL SYSTEM			
System Voltage	12 V		
Alternator Output	85 amps		
WORKING HYDRAULICS			
Standard Flow	18.3 gal (69 L)/min	20.9 gal (79.2 L)/min	
Optional High Flow	28.3 gal (107 L)/min	31.8 gal (20.2 L)/min	
Hydrostatic Pressure	3002 psi (20.7 MPa)	3045 psi (21 MPa)	
System Type	open	open	
Cycle Time, total	7.9 s	8.27 s	
Raise	3.9 s	3.66 s	
Dump	1.9 s	2.82 s	
Lower (empty, float down)	2.1 s	1.79 s	
TRAVELLING HYDRAULICS			
System Type	Closed	Closed	
Hydrostatic Pressure	5,075 psi (35 MPa)	5075 psi (35 MPa)	
Drive Chain Size	100 HS	100HS	
Max Travel speed	11 km/h	11.6 km/h	
Optional Max Travel Speed	18.7 km/h	23.1 km/h	
TIRES			
Ply Type	vacuum	vacuum	
Tire Size	10 - 16.5	12-16.5 TI200	
Ply Rating	8	12	

PERFORMANCE		375B	385B
Static Tipping Load		4,149 lb (1,886 kg)	4608 lb (2,090 kg)
Rated Load		1,900 lb (865 kg)	2304 lb (1,045 kg)
Boom Breakout Force		4,244 lbf (18.86 kN)	4568 lbf (20.3 kN)
Bucket Breakout Force		4,680 lbf (20.8 kN)	6705 lbf (29.8 kN)
Bucket Capacity		0.59 yd ³ (0.45 m ³)	0.65 yd ³ (0.5 m ³)
SERVICE CAPACITIES		375B	385B
Fuel Tank		26.4 gal (100 L)	29 gal (110 L)
Engine Oil		2.4 gal (9 L)	2.4 gal (9 L)
Cooling System		3.4 gal (13 L)	5.3 gal (20 L)
Hydraulic Reservoir		13.7 gal (52 L)	15.9 gal (60 L)
Hydraulic System Total		18.5 gal (70 L)	21.1 gal (80 L)
Chain Tanks, Each		2.1 gal (8 L)	3.2 gal (12 L)
DIMENSIONS		375B	385B
A. Maximum Hinge Pin Height		115.4 in (2,923 mm)	129.1 in (3278 mm)
B. Dump Clearance at Full Height		87.6 in (2,220 mm)	101.3 in (2572 mm)
D. Ground Clearance		8.0 in (204 mm)	7.9 in (200 mm)
E. Wheelbase		42.9 in (1,087 mm)	52.5 in (1334 mm)
G. Overall Length without Bucket		104.6 in (2,650 mm)	117 in (2973 mm)
H. Overall Height to Top of Cab		76.6 in (1,940 mm)	80.1 in (2034 mm)
L. Overall Length with Standard Bucket		135.4 in (3,432 mm)	151.6 in (3851 mm)
R1. Maximum Roll-back Angle at Full Height		95°	99°
R2. Bucket Rollback at Ground Level		30°	30°
R3. Maximum Dump Angle at Full Height		40°	39°
R4. Angle of Departure		26°	27°
R5. Front Clearance Radius with Bucket		71.0 in (1,800 mm)	91.5 in (2324 mm)
R6. Front Clearance Radius without bucket		53.9 in (1,365 mm)	55.7 in (1414 mm)
W2. Wheel Tread		52.7 in (1,335 mm)	60.5 in (1536 mm)
L1. Dump Reach at Full Height		21.3 in (540 mm)	23.1 in (587 mm)
Maximum Working Height at Full Height		148.9 in (3,774 mm)	164.4 in (4176 mm)
Overall Width with Standard Bucket		64.3 in (1,630 mm)	72.8 in (1850 mm)
Overall Width without Bucket		62.2 in (1,576 mm)	72.8 in (1850 mm)

DIMENSIONS

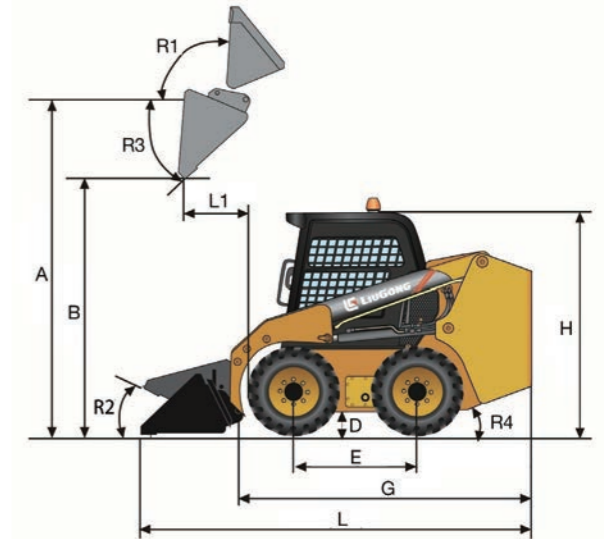
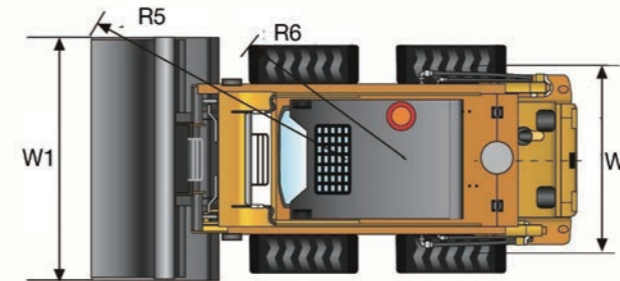

STANDARD EQUIPMENT

ENGINE SYSTEM

- Yanmar diesel engine, four cylinders
- Tier 4 / Stage IIIB emission standard
- 375B
 - Yanmar 4NV98CT-NLYS
 - Fuel tank 26.4 gal (100 L)
- 385B
 - Yanmar 4NV98C-PLYS
 - Fuel tank 29 gal (110 L)

TIRES

- Tubeless tyre

ATTACHMENT

- Quick coupler
- 375B
 - General bucket 0.59 yd³ (0.45 m³)
- 385B
 - General bucket 0.65 yd³ (0.5 m³)

OPERATOR ENVIRONMENT

- Open cab with FOPS & ROPS
- Standard seat with 2 in seat belt
- CE Extinguisher
- Hand throttle
- Control safety interlock

HYDRAULIC SYSTEM

- Hydraulic one-way self-leveling
- Auxillary hydraulic pipe

OTHERS

- Pilot Control
- English decals
- CE extinguisher
- North American Decals
- CE Decals

TRANSMISSION SYSTEM

- Hydraulic brake
- Single speed motor

OPTIONAL EQUIPMENT

OPERATOR ENVIRONMENT

- Enclosed cab, ROPS / FOPS
- AC and heater
- Foot throttle
- Radio with MP3
- Rear view mirrors
- Rotating beacon

TIRES

- Tire chains
- 375B
 - Solid tyre 22 x 7 x 16
 - Solid tyre 31 x 10 x 16
- 385B
 - Tubeless tyre 14-17.5 14 PR
 - Solid tyre 33x12x20

HYDRAULIC SYSTEM

- 375B
 - High flow 28.3 gal/min (107 L/min)
- 385B
 - High flow 31.7 gal/min (120 L/min)

ATTACHMENTS

- General bucket: 0.52 yd³ (0.4 m³), 64.3 in (1,630 mm) width
- General bucket: 0.52 yd³ (0.4 m³), bolt-on cutting edge
- General bucket: 0.59 yd³ (0.45 m³), bolt-on teeth
- General bucket: 0.65 yd³ (0.5 m³), bolt-on teeth
- 4 in 1 bucket: 0.59 yd³ (0.45 m³), 74 in (1,880 mm) width
- 4 in 1 bucket: 0.59 yd³ (0.45 m³), bolt-on teeth
- 4 in 1 bucket: 0.52 yd³ (0.4 m³), 64.2 in (1,630 mm) width
- Rock bucket: 0.52 yd³ (0.4 m³), 74 in (1,880 mm) width
- Pick-up broom
- Cold plander: working width 17.7 in (450 mm)
- Snow blade: swing angle of ±30°
- Grapple bucket: grapple diameter from 13.8 in to 25.6 in (350 to 650 mm)
- Pallet fork: teeth length 42.1 in (1,070 mm)
- Hydraulic hammer: SOOSAN SB40

- Material handling arm
- Trencher: working width from 3.9 in to 11.8 in (100 to 300 mm), max. depth 35.4 in (900 mm)
- Wear resistant drill pipe: length 1,600 mm and hole diameter 19.7 in (500 mm)
- Rock drill pipe, length 63 in (1,600 mm) hole diameter 19.7 in (500 mm)
- Arc-bucket, 0.59 yd³ (0.45 m³), width 61 in (1,550 mm)
- Snow blower: working width 72 in (1,830 mm)
- Single excavator arm: max. depth 74.3 in (1,886 mm)
- Vibratory drum compactors, working width 68.1 in (1,730 mm)

OTHERS

- License plate frame
- Other English decals
- Counterweight, 177 lbs (80 kg)
- 385B
 - Double speed motor



Guangxi LiuGong Machinery Co., Ltd.
No. 1 Liutai Road, Liuzhou, Guangxi, PR China
545007

T: +86 772 388 6124

E: overseas@liugong.com

www.liugong.com

Like and follow us:



LG-BP-375B/385B-T4-WW-A4-112017-ENG

LiuGong series of logos herein, including but not limited to word marks, device marks, letter of alphabet marks and combination marks, as the registered trademarks of Guangxi LiuGong Group Co., Ltd. are used by Guangxi LiuGong Machinery Co., Ltd. with legal permission, and shall not be used without permission. Specifications and designs are subject to change without notice. Illustrations and pictures may include optional equipment and may not include all standard equipment. Equipment and options varies by regional availability.